

# 120/240 TR-3 Volt Power Supply with APCL-5 FLASHCHANGER®



Automatic Power has developed a compact, high current power supply to operate with the APCL-5 FLASHCHANGER® where mains power is available. Designated the TR-3 Power Supply this unit is fitted in a standard flasher can (122mm x 19mm x 132mm) suitable mounting in the base of most marine lanterns. With the APCL-5 FLASHCHANGER® occupying the space of a lampchanger and the TR-3 power supply occupying the space of a flasher, virtually every optic of 140mm diameter or larger can be upgraded to operate 12 Volt, prefocussed, marine signal lamps over the range of .25 amps to 5.0 amps.

## APCL-5 FLASHCHANGER®

The TR-3 Power Supply allows the AC mains powered lights the advantage of operating standard direct current, four or six place, APCL-5 FLASHCHANGER® with selectable flash rhythms, automatic power driven lampchanging, adjustable pulse-width-modulated lamp voltage regulation, monitoring, synchronization, self-test function, communications port, lampout control terminal, photocell, and enhanced environmental protection.

## SPECIFICATIONS

- **Input Voltage:** 120 VAC or 240 VAC. 50 or 60 hertz
- **Output Voltage:** 13.0 volt nominal
- **Lamps:** 12-volt, P-30 prefocussed base, marine signal incandescent or halogen.
- **Output Current:** 3.5 Amps continuous (maximum).
- **Grounded in accordance with NEC Standards.**
- **Serviceability:** Large screw type terminals to accept 3/8 in. lugs. Nickel alloy plated copper terminals. Terminals for AC Input, ground and 12-Volt DC output.
- **Environmental:** Operating temperature -40C° to 85 C°. Relative humidity 0-100 percent. High temperature Salt fog. Terminals sealed with O-rings.

Heirs to the original 1928 patent for lampchangers and the pioneer in the electrification of aids to navigation, Automatic Power manufactures flashers and lampchangers to the quality and reliability standards demanded by the marine environment. Staff design engineers are able to adjust product specifications to specific customer needs.

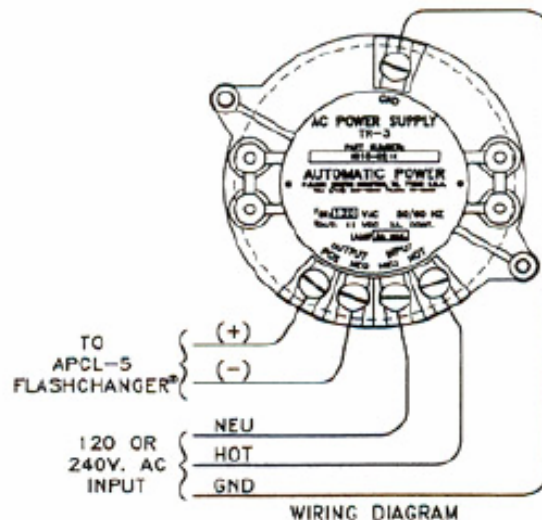
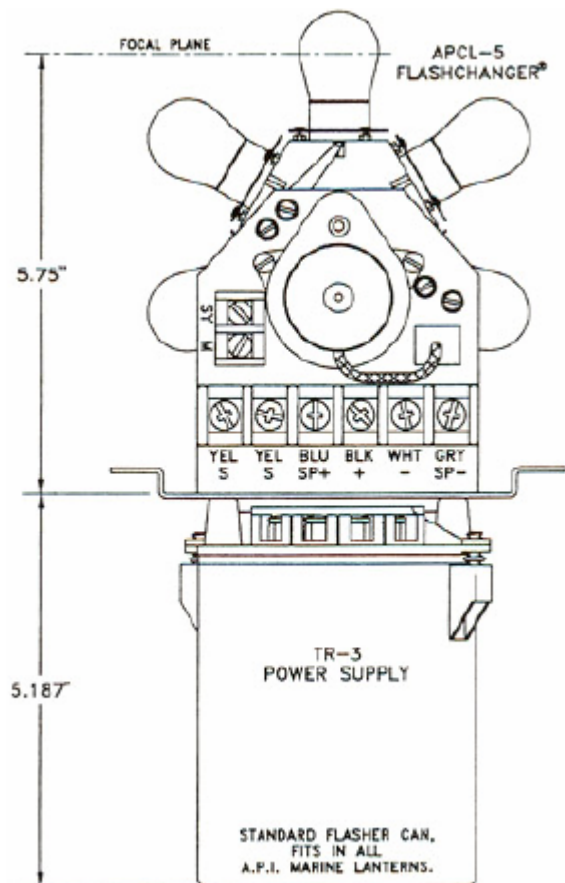

FLASHCHANGER® IS A REGISTERED TRADEMARK OF AUTOMATIC POWER INC.