

FA-240 RANGE LIGHT WITH LEDS



The FA-240 range light has been used on more leading lines than any optic in the world and it continues to set the standard in a unidirectional aid to navigation. It represents the optimum mix of high horizontal candlepower, vertical divergence to accommodate varying heights of eye of shipping, reliable output under varying environmental conditions, adaptability to different signaling requirements including wireless synchronization, simple logistics, and long service life with reduced spare parts requirements.

With the increase in development in port areas, it is becoming increasingly more difficult to distinguish the leading lights from the background lighting. Increasing the candlepower of the light and rhythmically flashing the lights give some improvement but the random nature of the flashing limits effectiveness. Synchronization of the flashing leading lights is known to greatly increase the conspicuity of the lights but it is costly to have a hardwire synchronization connection between the two lights.

To increase the conspicuity of leading lines, Automatic Power has developed the wireless UNIFLASH-III system for synchronizing FA-240 leading lights. This system receives the Global Positioning System (GPS) satellite signals and uses the decoded signal to synchronize the flashing of the leading lines. This system is a cost effective solution to synchronizing leading lines worldwide.

The FA-240 effectively addresses another common problem in designing leading lines. With its 2-degree vertical divergence, it is able to service a greater variation in heights of eye of mariners transiting a channel. This wide divergence also reduces the criticality of mounting and leveling of the optic and

reduces the vulnerability of the optic to lamp changing and lamp variations.

The FA-240 housing is made of compression-molded fiberglass, which has proven to be an exceptionally durable material in the marine environment. Two-silicone rubber lens O-rings provide an airtight seal. A stainless steel V-band allows easy access to the interior of the lantern. Electrical access is through 3/4" NPT threaded entries in the base of the lantern.

Now available with Automatic Power's 2X1 SE LED patented technology mounted in the same location as a lampchanger.

A range of Spredlite lenses is offered to assist in selecting the degree of horizontal divergence of a range light. Coverage limited to the channel width is rarely sufficient as the range lights are typically used to turn onto the channel as well as transit the channel. Divergence should be provided to assist in turning onto the channel.

The leading line or two-station range is the most effective lighting system for marking restricted pilotage waterways. The lights of each station are aligned when the ship is on the channel's centerline. The lights separate when the ship drifts to either side. This feature gives the pilot a "feel" for his position off the range since he can tell the direction and degree of drift. Course corrections can be evaluated immediately by whether the lights begin to "open" or "close".

The single station, "polychrome" (color-sectored) range, gives the pilot information that is limited to where he is at the current time: right, left or in the center of the channel. It may not give sufficient feedback for the pilot to determine if the ship's position is improving or worsening in order for him to make timely steering adjustments. The larger the vessel, the narrower the channel, the stronger the drift, the less effective the polychrome range.

Patent No.: US 7,534,009 B2

FORM N° 102809

PERFORMANCE

LAMP			FIXED INTENSITIES (Candela)			
LED	Volts	POWER	Flatlite*	3.5° Spredlite*	8° Spredlite*	30° Spredlite*
GREEN	12.0	3 W	26400	6600	4500	975
GREEN	12.0	1.5 W	13200	3300	2750	480
RED	12.0	3 W	32900	8240	5630	1220
RED	12.0	1.5 W	16450	4120	2815	610
AMBER	12.0	3 W	13160	3300	2250	480
AMBER	12.0	1.5 W	6580	1650	1120	240
WHITE	12.0	3 W	16450	4120	2815	610
WHITE	12.0	1.5 W	8225	2060	1410	355

Note: *Candela measured on axis. Spredlite lens spread is total beam to 50% of intensity. Vertical Divergence 5 degrees to 10%.

TECHNICAL DATA

- **LENS:** Flatlite, 3.5 degree, 8 degree and 30 degree Spredlite.
- **LED CONTROLLER:** 256 selectable flash rhythms, 10 levels of current to the LED array ranging from 0.3 watts to 3 watts, solar charge regulator, RS-485 & RS-232 monitoring and communications port, synchronization terminal, and external photocell. Interchangeable with CG-6P lampchanger.
- **LAMP:** 2x1 SE LED array (patent pending). (Green, red, amber, clear), 3 watts maximum power consumption. 50,000 hrs + life
- **UNIFLASH® III: (Optional)** Wireless synchronization system mounted in the FA-240 housing. Extremely low power consumption averaging 2 milliamps.
- **MATERIALS:** Acrylic lenses. Compression molded fiberglass housing, stainless steel fittings, silicone-rubber lens gaskets.
- **FINISH:** Grey.
- **ACCESSORIES:** Rifle-type aiming sights, Leveling and aligning adjustments in the base. Flat pad on top of unit for spirit level. Detachable sunshade. TR-3 Power Supply.
- **DIMENSIONS:** Height: 16 in X 12.5 in X 24 in. Weight: 28 pounds. Shipping Weight: 44 pounds. Shipping Carton: 16in. X27in. X 18in. (4.5 cu ft.).

UNIFLASH II ANTENNA

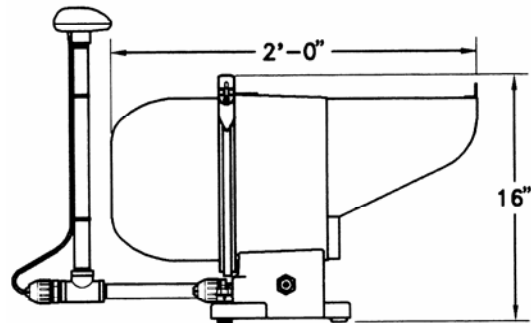

SIDE VIEW

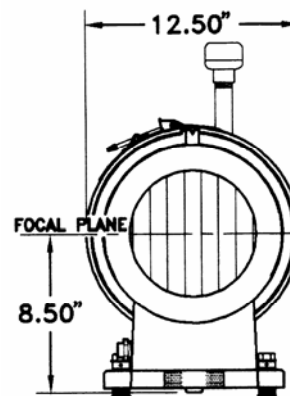

FRONT VIEW

UNIFLASH® is a registered trademark of Automatic Power, Inc.

www.automaticpower.com

Pharos Marine – England
Steyning Way, Hounslow
Middlesex, England TW4 6DL
Phone: 44-20-8538-1100
Fax: 44-20-8577-4170
sales@pharosmarine.com

Automatic Power – West Coast USA
250 Bel Marin Keys Blvd. B3
Novato, CA USA 94949
Phone: 415-382-6296
Fax: 415-382-6299
dolantp@aol.com

**AUTOMATIC POWER – HOUSTON
MAIN OFFICE & FACTORY**
213 Hutcheson St.
Houston, TX USA 77003
P.O Box 230738 (77223)
Phone: 713-228-5208
Fax: 713-228-3717
sales@automaticpower.com

Automatic Power – Gulf Coast USA
1340 Westbank Expressway
Westwego, LA USA 70094
Phone: 504-347-2384
Fax: 504-348-2306
dcummiskey@automaticpower.com

Pharos Marine – Singapore
35 Tannery Road
05-05 Tannery Block, Singapore
347740
Phone: 65-6747-9325
Fax: 65-6746-0478
abpharos@singnet.com.sg

Automatic Power – East Coast USA
204 Parkway Drive
Williamsburg, VA USA 23183
Phone: 757-253-2817
Fax: 757-220-8166
APIatlantic@aol.com

