

FA-232 & FA-390A SOUND SIGNALS



PURE TONE SIGNALS

The tuned steel drivers vibrate at a precise frequency and are acoustically coupled to the air through the horn.

The solid state power supplies invert the DC input to AC at the proper frequency to resonate the diaphragm. Horn impedance is adjusted to produce maximum sound for energy consumed.

Reliability is assured since all components are located within the emitter and sealed from the environment.

Electronic control (timer-oscillator) design allows a large number of custom coding characteristics. Remote control is independent of power connections.

The **FA-390A** is a particular variation of this system specifically designed for use as a Half Mile Fog Signal aboard petroleum structures and rigs in U.S. waters.

BELL AND GONG SIGNAL

The FA-232 Sound Signal is also available with an audio output which closely approximates that of a mechanically produced bell or gong tone. Such short-range signals are ideally suited to fixed-station applications when pure tone signals are objectionable because of population density. Also desirable to differentiate between two or more sound signals located in close proximity.

FA-232 OPTIONS

The **TR-2 Transformer-Rectifier**, which fits within the emitter dome, will convert 100-130 volt 50/60 Hz AC to correct horn input voltage.

Directional Plugs are available to limit audio output in certain (populated) areas.

A manual **Half-Power Switch** allows for 2 different audio intensities to be available (FA-232 Pure Tone Signal only).

SPECIFICATIONS

- **Nominal Input:** Voltage – 12 volts DC
Current – 2.2 amps
- **Nominal output:** 390Hz – 122.7 db @ 10.5V minimum battery voltage
- **Weight:** 124 lbs.
- **Domestic Shipping Weight:** 190lbs

FA 390A

U.S. Coast Guard approved for ½ mile range with 17.8 watts to emitter.

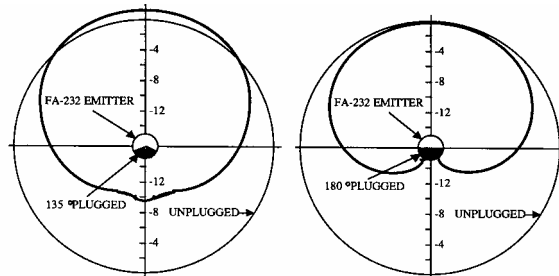

Directivity Patterns for Plugged FA-232/FA-390 Fog Horns

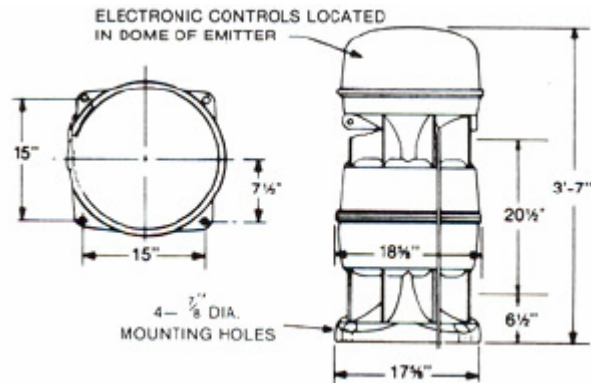

FA-232/FA-390A