

SINGLE LIFT ASSEMBLY CLASS A



The Automatic Power Class A Single Lift Assembly Aids to Navigation Package is a rugged compact unit designed for applications requiring a two mile sound signal and a single five mile marine lantern. It meets or exceeds U.S. Coast Guard requirements for Class A Aids to Navigation as specified in 33CFR sub-part 67. This galvanized steel self contained assembly includes a solar power system with batteries and battery box. The solar array can be positioned to assure it faces due south.

TECHNICAL DATA

- **Lantern:** FA-250 lanterns with 250 mm clear self washing lens. APL-1297 six place automatic repositioning lampchanger, APF-247P programmable flasher, quick flash characteristic, photocell and leveling bolts.
- **Sound Signal:** DA-8 two mile sound signal with a 2 second ON and 18 second OFF characteristic. (Programmable)
- **Solar array:** Site Determined
- **Batteries:** 30 day capacity for sound signal, 30 day capacity for lantern
- **Construction:** Steel, hot dip galvanized
- **Weight:** 1280 pounds

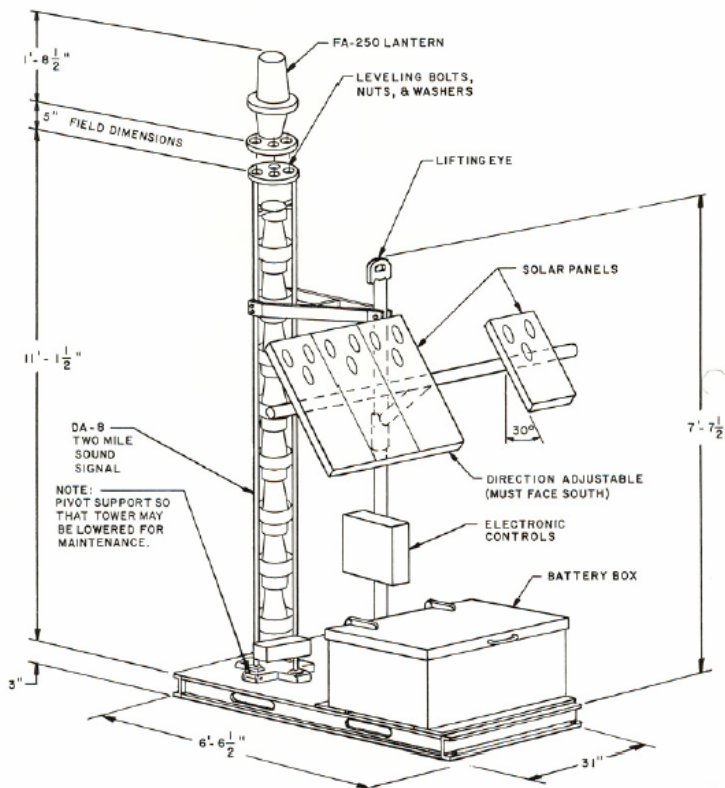

www.automaticpower.com

Pharos Marine – England
 Steyning Way, Houndslow
 Middlesex, England TW4 6DL
 Phone: 44-20-8538-1100
 Fax: 44-20-8577-4170
sales@pharosmarine.com

**AUTOMATIC POWER – HOUSTON
 MAIN OFFICE & FACTORY**
 213 Hutcheson St.
 Houston, TX USA 77003
 P.O Box 230738
 Phone: 713-228-5208
 Fax: 713-228-3717
sales@automaticpower.com

Pharos Marine – Singapore
 35 Tannery Road
 05-05 Tannery Block, Singapore
 347740
 Phone: 65-6-747-9325
 Fax: 65-6-746-0478
abpharos@singnet.com.sg

Automatic Power – West Coast USA
 26 Pizarro Ave.
 Novato, CA USA 94949
 Phone: 415-382-6296
 Fax: 415-382-6299
dlantp@aol.com

Automatic Power – Gulf Coast USA
 1340 Westbank Expressway
 Westwego, LA USA 70094
 Phone: 504-347-2384
 Fax: 504-348-2306
dcummiskey@automaticpower.com

Automatic Power – East Coast USA
 204 Parkway Drive
 Williamsburg, VA USA 23183
 Phone: 757-253-2817
 Fax: 757-220-8166
APlatlantic@aol.com