



OVERVIEW

The FLOB-249 LED Flashing Aviation Light is a low intensity, omnidirectional red/yellow obstruction light that complies with the requirements ICAO Annex 14 6.3.12 for mobile objects. The lantern is an adaptation of the OB-249 LED which complies to FAA L-810.

CERTIFICATES

FM Approved
NI/I/2/CD

KEY FEATURES

- Very high flux LEDs mounted on a STABRITE LED array system, driven by specially designed electronics
- The 3X4 LED array approximates an incandescent point light source which couples to the lens with a high degree of efficiency
- Proven lantern design with the flexibility to use the same housing and lens system for both LED and lamp changer systems, and ability to retrofit LEDs into existing installations
- At the regulated intensity, the LED has a rated life on the order of 100,000 hours
- Light operates at 40 flashes per minute
- Ability to accommodate an external photocell, solar array cable and battery cable
- Bird spike on top of optic
- Hinged at midpoint for re-lamping

PHYSICAL SPECIFICATIONS

Height	470 mm (18.5")
Weight	2.22 kg (4.9 lbs.)
Shipping Weight	4.5 kg (10 lbs.)
Input Power	2.4 Watts Over the Range of 10.7-30 VDC
Power Supply	12, 18 or 24 V Solar Power System; 12, 18 or 24 V Power Supply with Various AC Inputs; or 12/24 V Battery Charger/Battery Bank
Lens Type	155 mm Aviation Clear Acrylic Fresnel Lens
Lantern Housing	Molded Lexan® Lens Ring and Base
Mounting	4) 16 mm (5/8") Holes on a 200 mm (7 7/8") Bolt Circle, 90° Apart (3-Hole Mounting Pattern Also Available)
Candlepower	FAA Standards; Not Less Than 32.5 Candela (Peak) & 15 Candela at ± 5° at 10.5V for 2.4 Watts of Input Power
Beam	360° Horizontal – Not Obstructed By Standby Optic; Uniform within 15%
Aiming	Center of Vertical Beam is +10°
Ingress Rating	IP-56

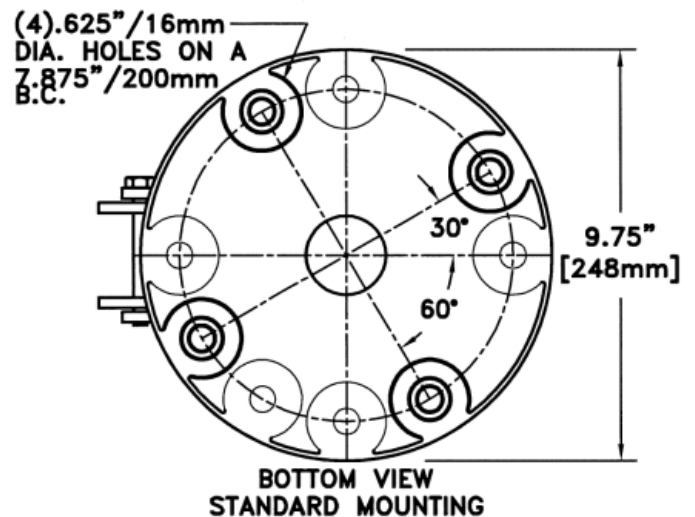
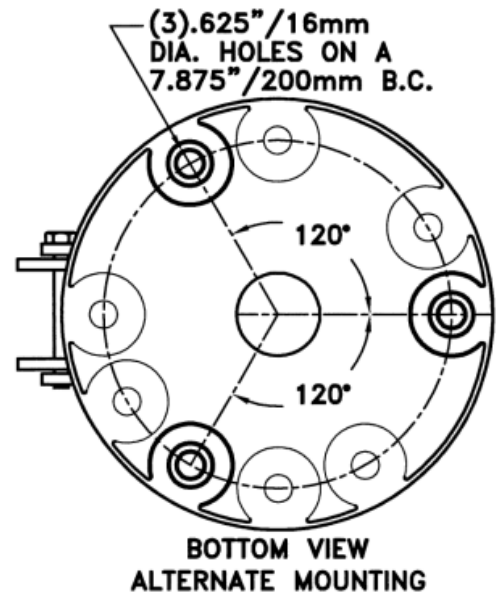
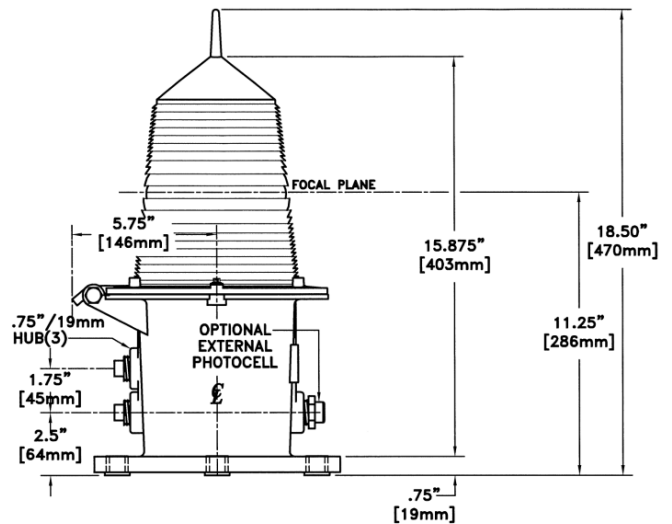

*All values are subject to change without notice.

Pharos Marine Automatic Power, Inc.
Houston, TX - USA
sales@automaticpower.com
Phone: +1-713-228-5208

Pharos Marine Automatic Power
Gray, LA - USA
rleblanc@automaticpower.com
Phone: +1-985-223-8700

Pharos Marine Automatic Power, Ltd.
London, UK
sales@pharosmarine.com
Phone: +44-20-8538-

AB Pharos Marine Pte.
Singapore
sales@pharos-api.com
Phone: +65-6747-9325