



FA-249EX-SS

Zone 1 Stainless Steel LED Marine Lantern

3-10 NM at 0.74T



OVERVIEW

Zone 1 certified LED marine lantern that is rugged, compact and lightweight, particularly suitable for highly corrosive environments due to a complete 316 Stainless Steel body. Compliant with IALA and DECC recommendations. The FA-249EX is ideal for fixed offshore structures, jetty lights and buoys.

CERTIFICATES

- ATEX Certificate Number: ITS16ATEX101123X
- IECEx Certificate Number: IECEx ITS 16.0053X
- Coding: Ex II 2 G Ex db op is IIB T5 Tamb -20°C - +55°C Gb (-40° optional)

KEY FEATURES

- 316L Stainless Steel body
- Designed to withstand harsh marine environments
- Low power consumption
- Ability to integrate with wide array of power systems
- Factory preset flash characteristics to customer specifications
- Ingress Protection: IP-66

OPTIONAL FEATURES

- Uniflash Series GPS synchronizing system
- Remote monitoring
- 365 day timer (Astronomical timer)

PERFORMANCE FEATURES

- Range: 3 - 10 NM
- 255 + 1 special programmable position
- Software programmable:
 - Photocell
 - Low voltage disconnect
 - Special flash rhythm
 - Specialized current settings
 - Solar charge control voltage setting
- 360° visibility
- Vertical Divergence: 20° at 10% and 7° at 50%
- High-efficiency TracSwitcher current controls; 82% of the battery current reaches the LED array on flash; 2mA idle current between flashes

MECHANICAL SPECIFICATIONS

Height	441mm
Depth	305mm
Weight	8kg
Mounting	4x16mm holes on 200mm PCD (3-Hole pattern also available)
Lens Type	155mm 360° Visibility Acrylic Fresnel Lens
Available Colours	IALA White, Red, Green & Amber

ELECTRICAL SPECIFICATIONS

Input Voltage	6, 12 or 24V DC 120 or 230V AC
Power Consumption	3 - 24W (Range dependent)

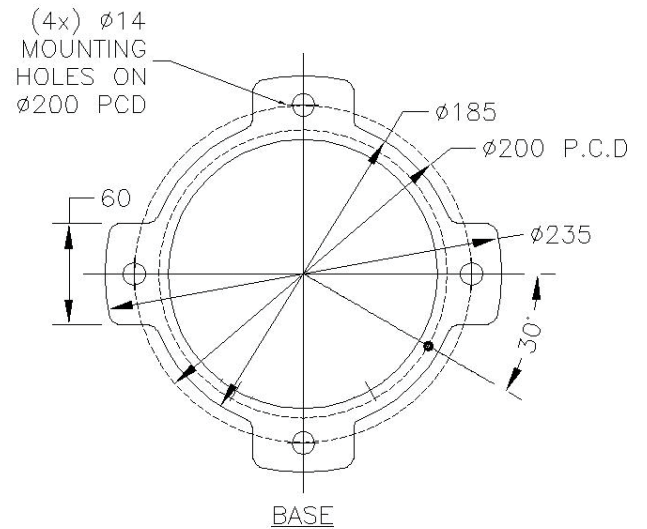
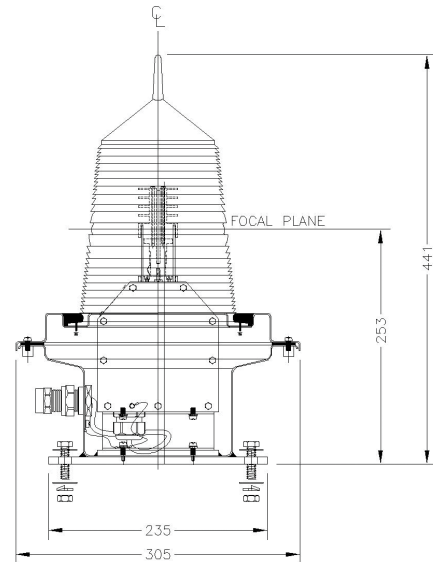

**All values are subject to change without notice.*

Pharos Marine Automatic Power, Inc.
Houston, TX - USA
sales@automaticpower.com
Phone: +1-713-228-5208

Pharos Marine Automatic Power
Gray, LA - USA
rleblanc@automaticpower.com
Phone: +1-985-223-8700

Pharos Marine Automatic Power, Ltd.
London, UK
sales@pharosmarine.com
Phone: +44-20-8538-

AB Pharos Marine Pte.
Singapore
sales@pharos-api.com
Phone: +65-6747-9325